

PAT.



株式会社 **MST** コーポレーション

국성인터내셔널(주)

서울 : 경기도 화성시 동탄순환대로 830 SK V1 Center V1동 1510호

T. 031-630-2111~2 F. 031-630-2110

대구 : 대구시 북구 유통단지로 16 (산격동, 산업빌딩 5층)

T. 053-604-0521~4 F. 053-604-0525 E-mail : kuksung@kuksung.com

# MST

5 , 3 ( + ) 가  
[ ] , [ ]

가 가

2 ISO-HSK [ ] [ ] ,

가

가 가 [ ] [ ] ,

가

5

3

+

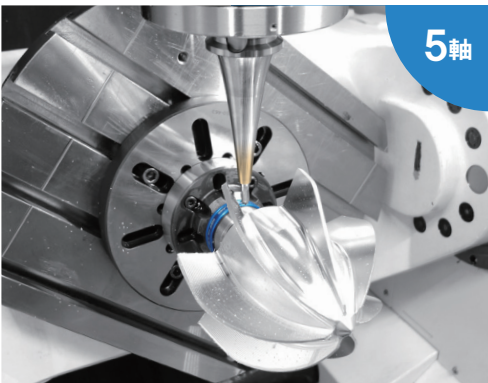

5軸

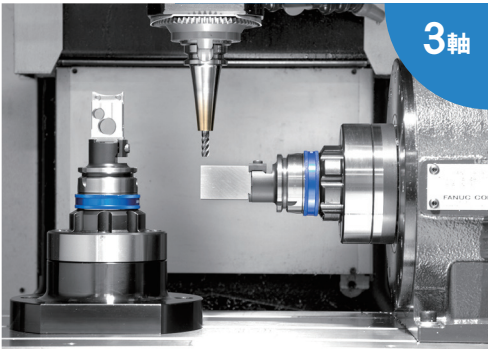
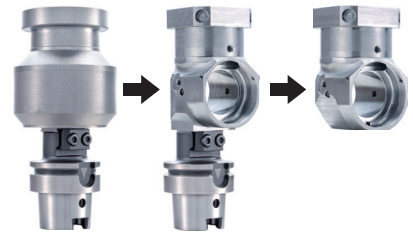
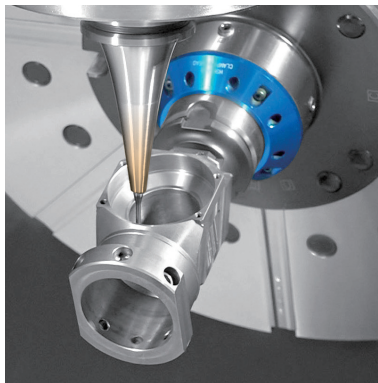

3軸

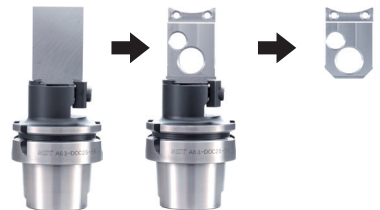
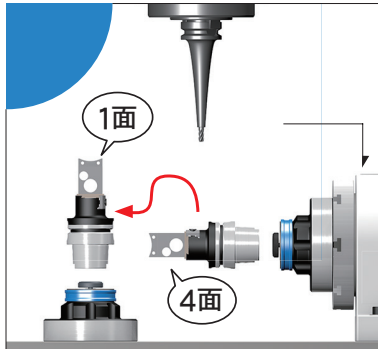

HSK(2 )

+

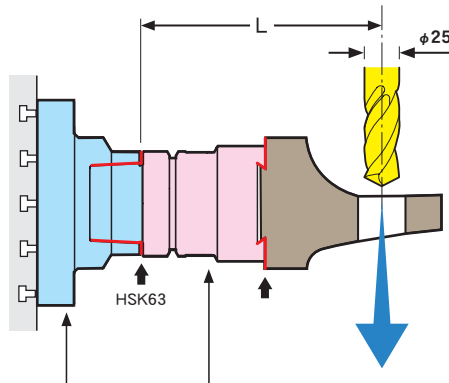
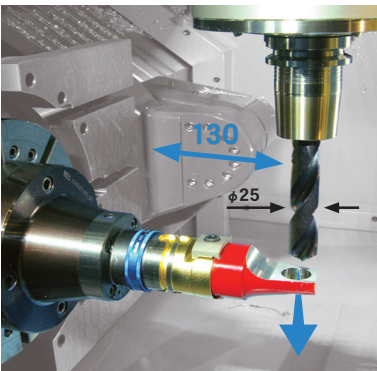

가

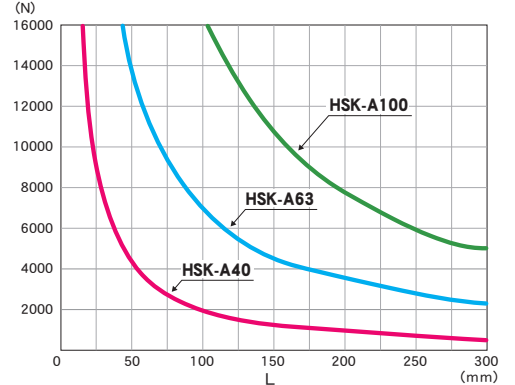

( , )

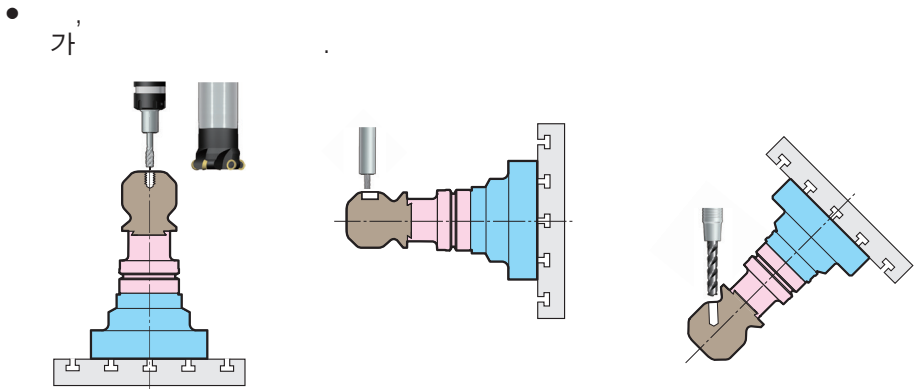
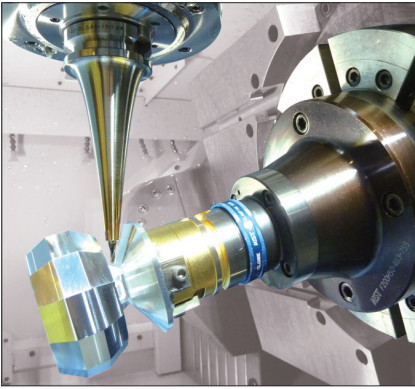

5 , 5

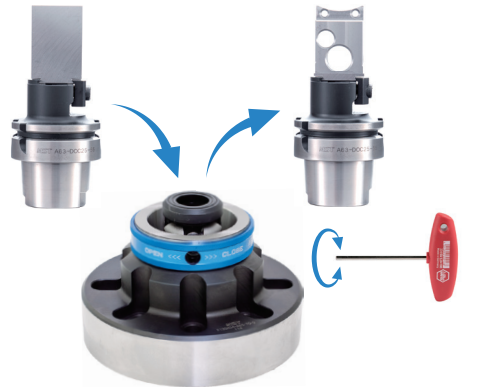

- 가
- 가

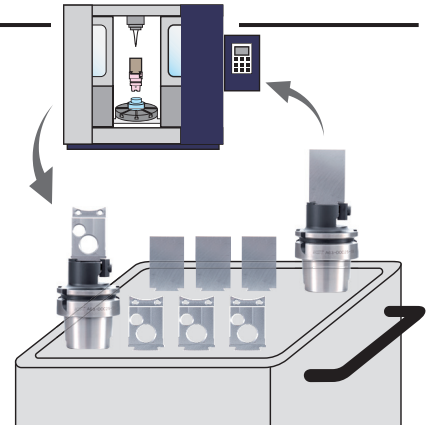
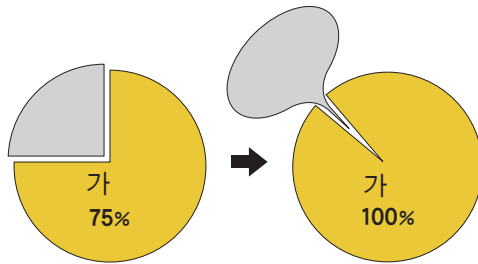

$2\mu\text{m}/L$   
 Z軸  
 $1\mu\text{m}$   
 $0.1\sim 0.3\text{mm}/D$

L=3×D	D	L
A40	40	120
A63	63	190
A100	100	300

BLUM

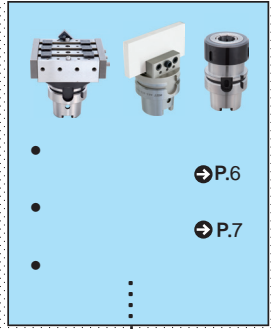
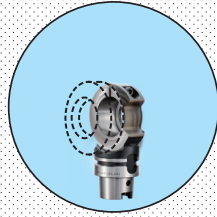
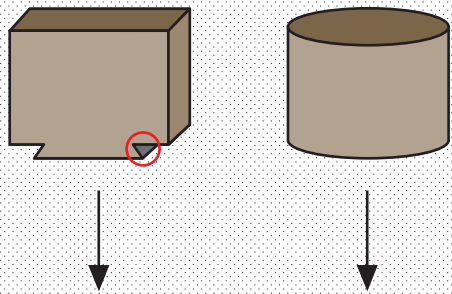

HSK-A40  
HSK-A63  
HSK-A100

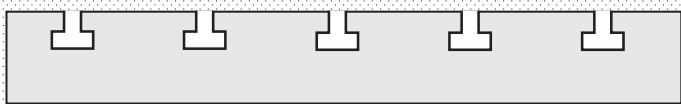
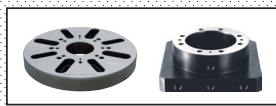
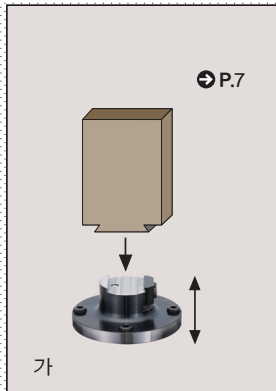

( )

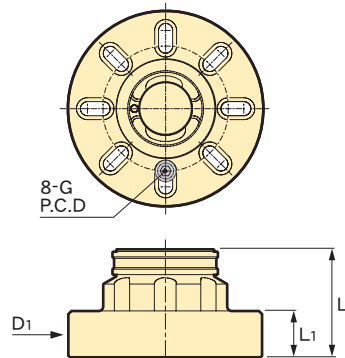
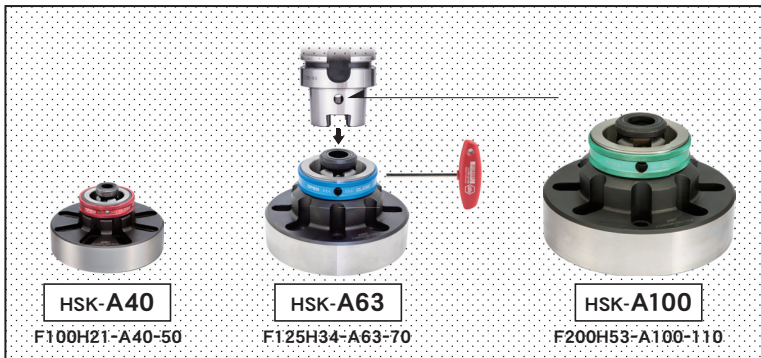

		L	$\phi D_1$	L1	G	P.C.D.		Kg
<b>F 100H21-A40 - 50</b>	HSK-A40	50	100	25	M 6×30	55~ 85	10(kN)	1.7
<b>F 125H34-A63 - 70</b>	HSK-A63	70	125	30	M 8×35	80~100	20	3.8
<b>F 200H53-A100-110</b>	HSK-A100	110	200	50	M12×50	125~160	30	14



가

		T	$\phi D$	$\phi H$	G1	G2	G3	P.C.D.	Kg
<b>F160H32-A40</b>	HSK-A40	20	160	32	M 5×20	M 6×20	M 6	80~125	2.6
<b>F200H32-A40</b>	HSK-A40	25	200		M 8×25	M10×25		100~160	5
<b>F160H50-A63</b>	HSK-A63	20	160	50	M 5×20	M 6×20	M 6	80~125	2.4
<b>F200H50-A63</b>	HSK-A63	25	200		M 8×25	M10×25		100~160	4.7
<b>F250H50-A63</b>		30	250	50	M10×30	M12×30	M12	140~200	9.4
<b>F250H80-A100</b>	HSK-A100	30	250	80	M10×30	M12×30	M12	140~200	8.7

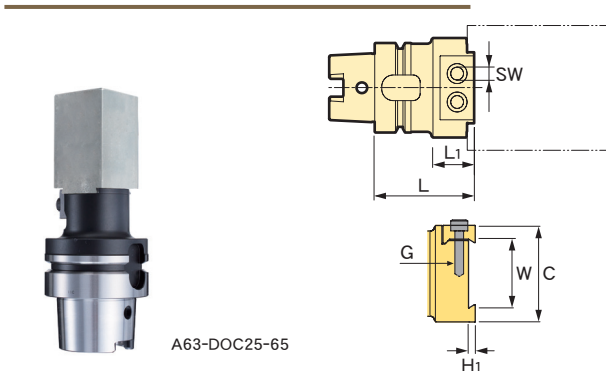
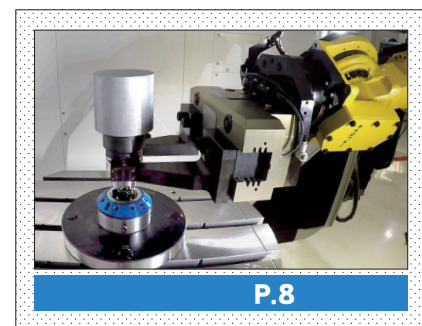

	L	L1	$\phi C$	W	H1	G	SW	Kg
<b>A40 -DOC 17.5-55</b>	55	25	30	17.5	2	M 5	4	0.4
<b>-DOC 25 -55</b>		28	40	25	3	M 6	5	0.6
<b>-DOC 35 -55</b>		25	50	35				0.7
<b>-DOC 50 -60</b>	60	30	70	50	5	M 8	6	1.2
<b>A63 -DOC 25 -65</b>	65	27	40	25	3	M 6	5	1.2
<b>-DOC 35 -65</b>			50	35				1.3
<b>-DOC 50 -70</b>	70	30	70	50	5	M 8	6	1.8
<b>-DOC 70 -75</b>	75	35	100	70		M10	8	3
<b>A100-DOC 35 -70</b>	70	27	50	35	3	M 6	5	3.3
<b>-DOC 50 -75</b>		32	70	50	5	M 8	6	3.8
<b>-DOC 70 -75</b>		35	100	70		M10	8	5
<b>-DOC100 -85</b>	85	40	140	100	10			7.7

가

가 가

	W	H	P	SW	SD
<b>DOC 17.5</b>	17.5	2.5	2.5	4	2
<b>DOC 25</b>	25	3.5		6	2.5
<b>DOC 35</b>	35		5.5	8	
<b>DOC 50</b>	50	5.5	9	10	4
<b>DOC 70</b>	70		18	12	
<b>DOC100</b>	100	10.5	26	15	

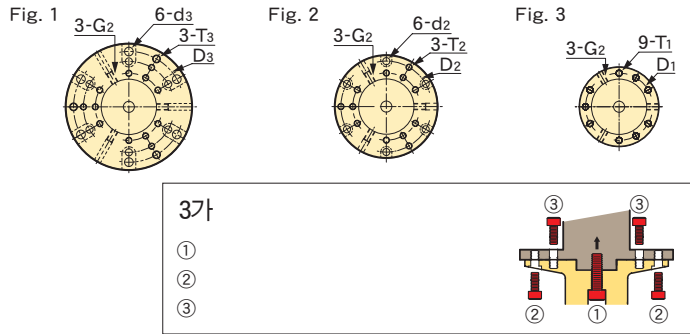
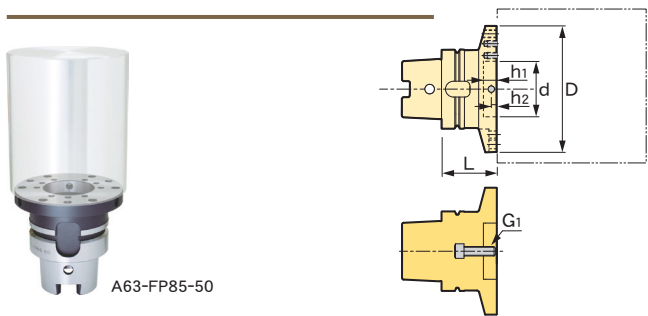

	Fig.	L	φD	φD1	φD2	φD3	φd	h1	h2	T1	T2	T3	φd2	φd3	G1	G2	KG
<b>A40 -FP40 -35</b>	3	35	40	32	—	—	25	12	4	M4×6	—	—	—	—	M 6×15	M4×8	0.3
	2	40	63	—	50	—	$25^{+0.053}_{+0.020}$	—	—	—	M5	—	5.5	—	M 6×20	—	0.5
<b>A63 -FP63 -45</b>	3	45	63	50	—	—	40	13	5	M5×8	—	—	—	—	M10×20	M6×10	0.9
	2	50	85	—	73	—	$40^{+0.064}_{+0.025}$	—	—	—	M6	—	6.6	—	M10×25	—	1.2
	1	55	110	—	95	—	—	—	—	—	M6×9	M 8	9	—	M10×30	—	1.7
<b>A100-FP100-55</b>	3	55	100	85	—	—	70	17	7	M8×12	—	—	—	—	M12×25	M8×16	3.0
	2	65	130	—	115	—	$70^{+0.076}_{+0.030}$	—	—	—	M8	—	9	—	M12×35	—	4.2
	1	70	160	—	140	—	—	—	—	—	M8×12	M10	11	—	M12×40	—	5.3

M6 (G1)\*1 (G2)\*3  
 M6 (M5)\*3 (A63-FP85-50 / A63-FP110-55)

(G1) 가 (G2)

		φD4	φD5	h	KG
IR15-A40 FP	HSK-A40	$15^{0}_{-0.027}$	25	15	0.05
IR25-A63 FP	HSK-A63	$25^{0}_{-0.033}$	40	16	0.1
IR40-A100FP	HSK-A100	$40^{0}_{-0.039}$	70	20	0.5

		Fig.	φD	φD1	φd	H1	H2	H	T1	G1	G2	G3	KG
<b>RS-A63 -A40</b>	<b>A63 -FP 63-45</b>	1	40	32	25	12	4	50	M4×6	M 6×20	M4×8	M5×16	0.5
	<b>-FP 85-50</b>	—	$40^{+0.064}_{+0.025}$	—	—	—	—	—	—	—	—	—	—
	<b>-FP110-55</b>	—	$40^{+0.064}_{+0.025}$	—	—	—	—	—	—	—	—	—	—
<b>RS-A100-A40</b>	<b>A100-FP100-55</b>	2	40	32	25	12	4	60	M4×6	M 6×20	M4×8	M8×25	1.5
	<b>-FP130-65</b>	—	$40^{+0.053}_{+0.020}$	—	—	—	—	—	—	—	—	—	—
	<b>-FP160-70</b>	—	$40^{+0.053}_{+0.020}$	—	—	—	—	—	—	—	—	—	—
<b>RS-A100-A63</b>	<b>A100-FP100-55</b>	1	63	50	40	13	5	55	M5×8	M10×20	M6×10	M8×25	1.7
	<b>-FP130-65</b>	—	$63^{+0.053}_{+0.020}$	—	—	—	—	—	—	—	—	—	—
	<b>-FP160-70</b>	—	$63^{+0.053}_{+0.020}$	—	—	—	—	—	—	—	—	—	—

(G1)×1 (G3)×3

(G2)×3

(G1)

(G2)

가

	Fig.	□S	B	W	G ( )	L	L1	KG	
<b>A63 -DOV 90</b>	1	—	3	90	12~73	20-M4(6)	85	35	3.8
<b>110I</b>	2	110	—	—	36~80	24-M8(10)	90	35	5.7
<b>A100-DOV140</b>	1	—	5	140	12~73	30-M4(6)	100	35	7.7
<b>140I</b>	2	140	—	—	36~110	52-M8(10)	100	35	9.9

• 8mm

가 (JAW)

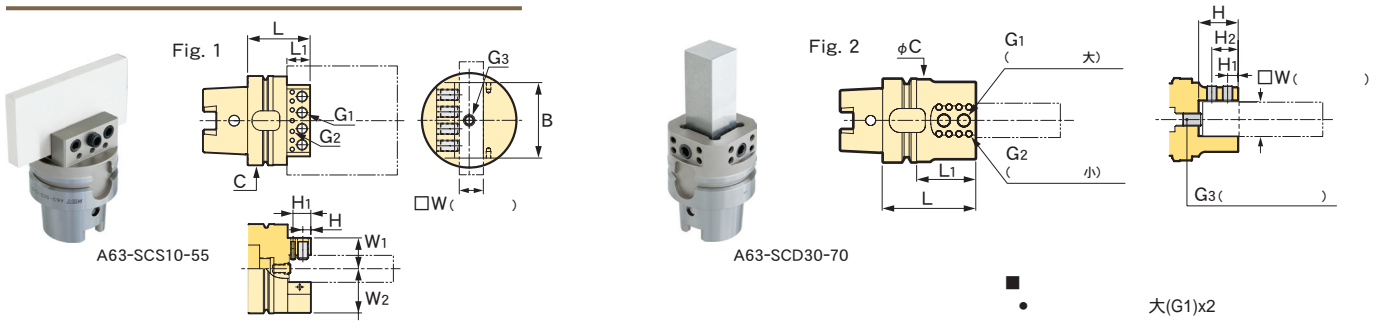
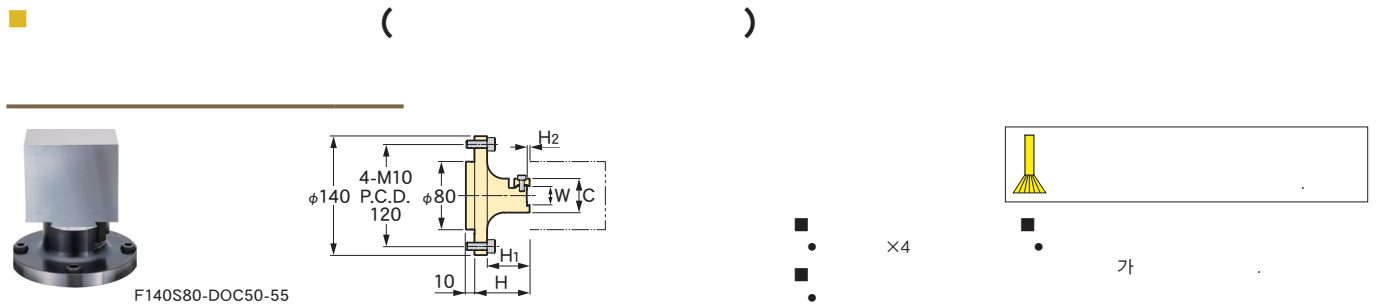

	Fig.	□W	W <sub>1</sub>	W <sub>2</sub>	B	L	L <sub>1</sub>	φC	H	H <sub>1</sub>	H <sub>2</sub>	( G <sub>1</sub> )	G <sub>2</sub>	G <sub>3</sub>	kg			
<b>A40 -SCS10-40</b>	1	5 ~ 10	13	18.6	30	40	11	39	4.5	—	—	M 6×10	—	M 6	0.5			
<b>-SCD20-55</b>	2	15 ~ 20	—	—	—	55	30	49	25	11	—	M 8×16	M4	M10	0.5			
<b>A63 -SCS10-55</b>	1	5 ~ 10	20	23.5	50	55	21	62	7.5	17	—	M10×15	M5	M10	1.1			
<b>-SCS20-55</b>		15 ~ 20	25	28.5														
<b>-SCD20-65</b>	2	15 ~ 20	—	—	—	65	30	49	25	11	—	M 8×16	M4	M10	1.2			
<b>-SCD25-70</b>		20 ~ 25	—	—		70	35	56	30	8	20				—	1.3		
<b>-SCD30-70</b>		25 ~ 30	—	—		—	44	62	35	9	24				M10×20	M5	1.4	
<b>-SCD40-85</b>		35 ~ 40	—	—		—	85	52	76	45	12				30	M12×20	M6	1.9
<b>A100 -SCS20-70</b>	1	12 ~ 20	29.5	34	80	70	26	99	9	20	—	M12×20	M5	M12	3.6			
<b>-SCS30-70</b>		22 ~ 30	34.5	39														
<b>-SCD20-70</b>	2	15 ~ 20	—	—	—	70	30	49	25	11	—	M 8×16	M4	M10	3			
<b>-SCD25-75</b>		20 ~ 25	—	—		75	35	56	30	8	20				—	3.4		
<b>-SCD30-80</b>		25 ~ 30	—	—		—	80	—	62	35	9				24	M10×20	M5	3.5
<b>-SCD40-90</b>		35 ~ 40	—	—		—	90	45	76	45	12				30	M12×20	M6	3.9



	H	H <sub>1</sub>	H <sub>2</sub>	φC	W	kg
<b>F140S80-DOC 17.5-60</b>	60	45	2	30	17.5	2.5
<b>-DOC 25 -60</b>			3	40	25	2.6
<b>-DOC 35 -55</b>	55	40		50	35	2.8

	H	H <sub>1</sub>	H <sub>2</sub>	φC	W	kg
<b>F140S80-DOC 50-55</b>	55	40	5	70	50	3.4
<b>-DOC 70-55</b>				100	70	4.7
<b>-DOC100-55</b>				140	100	5.5

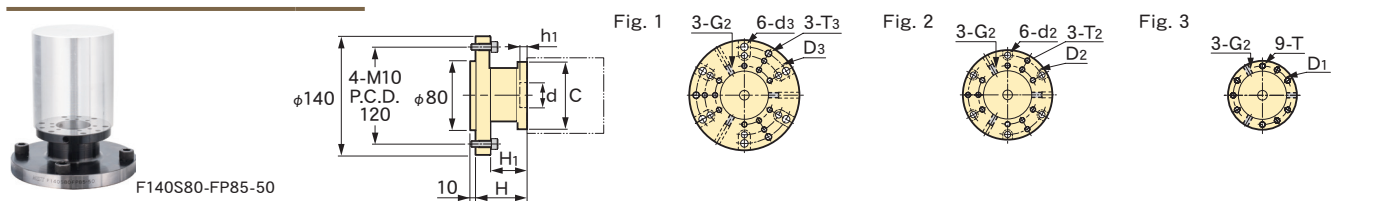
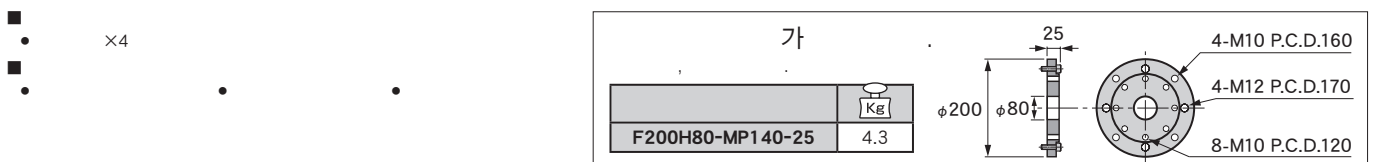

	Fig.	H	H <sub>1</sub>	φC	φD <sub>1</sub>	φD <sub>2</sub>	φD <sub>3</sub>	φd	h <sub>1</sub>	T <sub>1</sub>	T <sub>2</sub>	T <sub>3</sub>	d <sub>2</sub>	d <sub>3</sub>	G <sub>2</sub>	kg
<b>F140S80-FP 63-50</b>	3	50	25	63	50	—	—	40	13	M5×8	—	—	—	—	M6×10	2.6
<b>-FP 85-50</b>	2			85		73					M6		6.6			3.1
<b>-FP110-70</b>	1	70	45	110			95				M6×9	M8		9		3.7
<b>-FP130-75</b>	2	75		130	85	115	—	70	17	M8×12	M8	—	9	—	M8×16	5.5



	kg
<b>F200H80-MP140-25</b>	4.3

( )

가

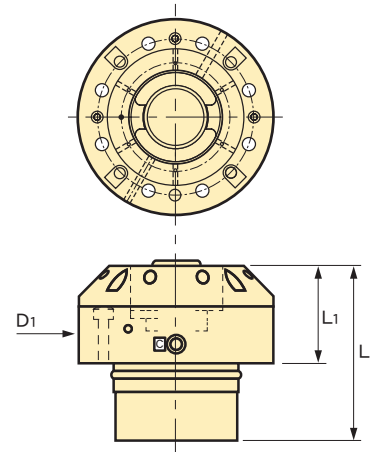
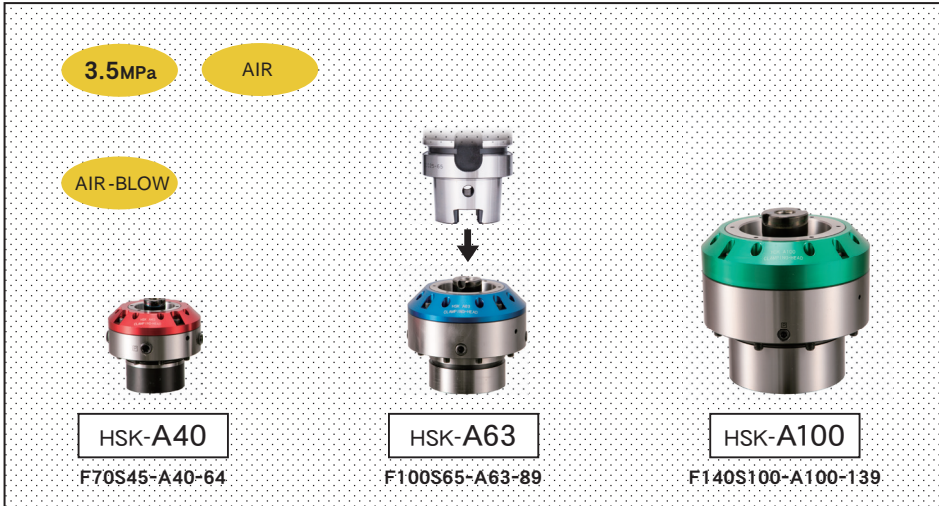

:3.5MPa

		L	$\phi D_1$	L <sub>1</sub>			
<b>F70S45 -A40 - 64</b>	HSK-A40	64	70	35	6 (kN)	50 (kg)	1.1
<b>F100S65 -A63 - 89</b>	HSK-A63	89	100	50	24	140	3.1
<b>F140S100-A100-139</b>	HSK-A100	139	140	80	55	640	9.7

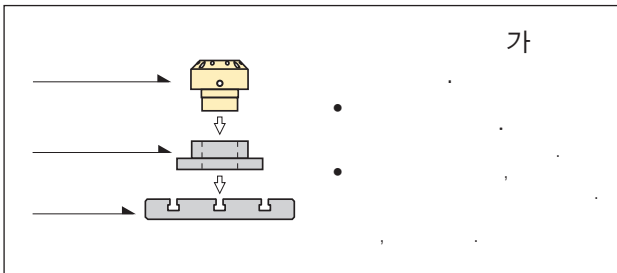

가

