

ARES NT

BRIDGE TYPE CNC COORDINATE MEASURING MACHINE

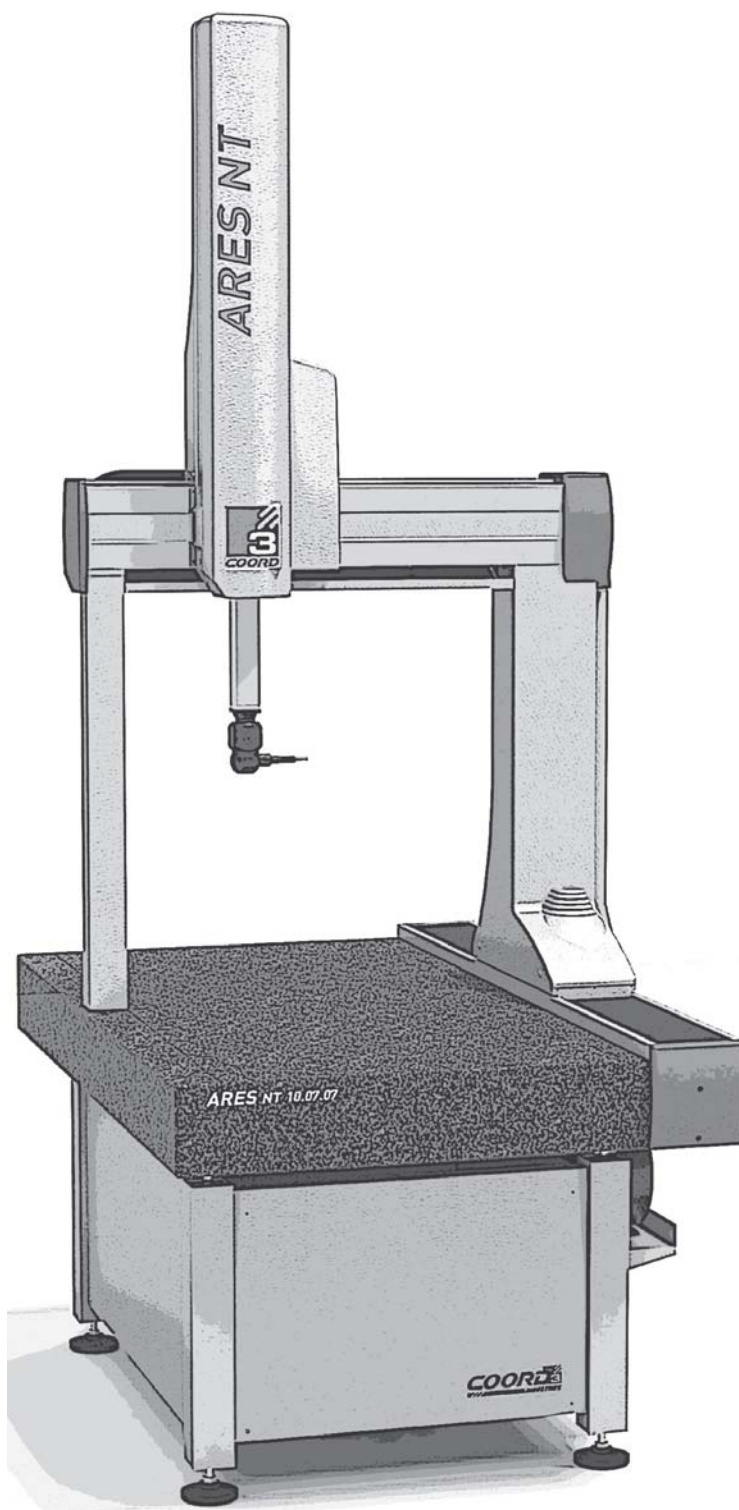

ARES NT



STRUCTURE:	CNC Bridge Type Coordinate Measuring Machine with alloy bridge frame on granite base
SURFACE PLATE:	Granite table with integrated guide-ways with flatness to DIN876/III and M8 threaded insert grid
GUIDEWAYS:	X axis machined into granite table Y axis micro-machined and hard anodized alloy extrusions Z axis Silicon Carbide extrusion (NT only, aluminum alloy extrusion on std)
DRIVE SYSTEMS:	CNC drive via DC motors with zero hysteresis friction drive on steel bar on all axes
BEARING SYSTEM:	Air bearings to all axes
MEASURING SYSTEM:	High resolution (0,1µm) free floating linear scales mounted in carriers
COUNTERBALANCE:	Adjustable pneumatic on Z ram
THERMAL COMPENSATION:	Optional Wireless multi-sensors for measuring scales and part (Optional)

ARES NT 05.05/07.05/07.07: SPECIFICATIONS

Models	Maximum Permissible Error ISO 10360-2 / ISO 10360-4															Max. 3D Pos. Speed	Max. 3D Accel.			
	T ₁ : 18±22 °C									T ₂ : 16±26 °C										
	PH10T/M/PH20-TP20			PH10T/M-TP200			PH6M/PH10M-SP25			PH10T/M/PH20-TP20		PH10T/M-TP200		PH6M/PH10M-SP25						
	⁽¹⁾ MPE _E	⁽²⁾ MPE _P		⁽¹⁾ MPE _E	⁽²⁾ MPE _P		⁽¹⁾ MPE _E	⁽²⁾ MPE _P	⁽³⁾ MPE _{THP}	⁽¹⁾ MPE _E	⁽²⁾ MPE _P	⁽¹⁾ MPE _E	⁽²⁾ MPE _P	⁽¹⁾ MPE _E	⁽²⁾ MPE _P			⁽³⁾ MPE _{THP}		
[µm]		[µm]		[µm]			[µm]		[µm]		[µm]			[mm/s]	[mm/s ²]					
xx.05.05	2,0 + L/333	2,0		1,8 + L/333	1,8		1,8 + L/333	1,8	3,9/120	2,0 + L/250	2,0		1,8 + L/250	1,8		1,8 + L/250	1,8	3,9/120	500	1500
xx.07.05	2,1 + L/333	2,1		1,9 + L/333	1,9		1,9 + L/333	1,9	4,0/120	2,1 + L/250	2,1		1,9 + L/250	1,9		1,9 + L/250	1,9	4,0/120	500	1500
xx.07.07	2,5 + L/300	2,5		2,3 + L/300	2,3		2,3 + L/300	2,3	4,5/120	2,5 + L/200	2,5		2,3 + L/200	2,3		2,3 + L/200	2,3	4,5/120	500	1200

Performance data are only valid if the following specifications are met:
 - PH10T/M/PH20-TP20/TP200: Tip diameter Ø 4 mm x Stylus length 10 mm
 - PH6M/PH10M-SP25: SM1, Stylus Ø 5 mm x 50 mm
 - L = measuring length in mm
 - CMM equipped with Multisensor temperature compensation system (Optional)

- Ambient temperature Range:
 T₁ : 18 ± 22 °C; Max. Gradients : 0,5 °K/h - 2,0 °K/24h - 0,5 °K/m
 T₂ : 16 ± 26 °C; Max. Gradients : 1,0 °K/h - 5,0 °K/24h - 1,0 °K/m
⁽¹⁾ Maximum Permissible Error of indication for size measurement according ISO 10360-2
⁽²⁾ Maximum Permissible Probing Error according ISO 10360-2
⁽³⁾ Maximum Permissible Scanning Probing Error according ISO 10360-4, applicable to the SP25M probes only

ARES 05.05/07.05: SPECIFICATIONS

Models	Maximum Permissible Error ISO 10360-2 / ISO 10360-4															Max. 3D Pos. Speed	Max. 3D Accel.			
	T ₁ : 18±22 °C									T ₂ : 16±26 °C										
	PH10T/M/PH20-TP20			PH10T/M-TP200			PH6M/PH10M-SP25			PH10T/M/PH20-TP20		PH10T/M-TP200		PH6M/PH10M-SP25						
	⁽¹⁾ MPE _E	⁽²⁾ MPE _P		⁽¹⁾ MPE _E	⁽²⁾ MPE _P		⁽¹⁾ MPE _E	⁽²⁾ MPE _P	⁽³⁾ MPE _{THP}	⁽¹⁾ MPE _E	⁽²⁾ MPE _P	⁽¹⁾ MPE _E	⁽²⁾ MPE _P	⁽¹⁾ MPE _E	⁽²⁾ MPE _P			⁽³⁾ MPE _{THP}		
[µm]		[µm]		[µm]			[µm]		[µm]		[µm]			[mm/s]	[mm/s ²]					
xx.05.05	2,2 + L/300	2,2		2,0 + L/300	2,0		2,0 + L/300	2,0	4,0/120	2,2 + L/200	2,2		2,0 + L/200	2,0		2,0 + L/200	2,0	4,0/120	500	1500
xx.07.05	2,5 + L/300	2,5		2,3 + L/300	2,3		2,3 + L/300	2,3	4,6/120	2,5 + L/200	2,5		2,3 + L/200	2,3		2,3 + L/200	2,3	4,6/120	500	1500

Performance data are only valid if the following specifications are met:
 - PH10T/M/PH20-TP20/TP200: Tip diameter Ø 4 mm x Stylus length 10 mm
 - PH6M/PH10M-SP25: SM1, Stylus Ø 5 mm x 50 mm
 - L = measuring length in mm
 - CMM equipped with Multisensor temperature compensation system (Optional)

- Ambient temperature Range:
 T₁ : 18 ± 22 °C; Max. Gradients : 0,5 °C/h - 2,0 °C/24h - 0,5 °C/m
 T₂ : 16 ± 26 °C; Max. Gradients : 1,0 °C/h - 5,0 °C/24h - 1,0 °C/m
⁽¹⁾ Maximum Permissible Error of indication for size measurement according ISO 10360-2
⁽²⁾ Maximum Permissible Probing Error according ISO 10360-2
⁽³⁾ Maximum Permissible Scanning Probing Error according ISO 10360-4, applicable to the SP25M probes only

PERFORMANCE VERIFICATION

MPE_E : Maximum Permissible Error of indication for size measurement

Measurement of a set of 5 sizes, taken through two opposite probing points on two nominally parallel planes. The set of 5 sizes is placed in 7 different positions/directions within the measuring volume. Each size is measured 3 times for a total of 105 measurements. All 105 measurements (100%) must be within the specified MPE_E.

MPE_P : Maximum Permissible Probing Error

A reference sphere is measured with 25 equally distributed probeings. The probing performance shall be verified in one position, placed in the middle of the CMM measure volume. Using all 25 measurements, compute the Gaussian associated sphere. For each of the 25 measurements, calculate the Gaussian radial distance R. Calculate the probing error P, as the range of the 25 Gaussian distances, Rmax - Rmin. The probing error P must be within the specified MPE_P.

MPE_{THP/t} : Maximum Permissible Scanning Probing Error

MPE_{THP/t} is the Maximum Permissible Scanning Probing Error of the range of all measured sphere radii (sphere form error), with high point density and predefined path scanning, where t is the specified time (seconds) needed to perform the verification test. The scanning probing performance shall be verified in one single position, placed in the middle of the CMM measure volume. A reference sphere is measured by scanning 4 target scan lines to determine the range of the radial distance R. The scanning probing error THP is calculated as the range of sphere radii between the measured centre and all of the valued scan points. The measured THP and the time to perform the scanning test must be within the specified MPE_{THP/t}.

STROKES, DIMENSIONS, WEIGHTS

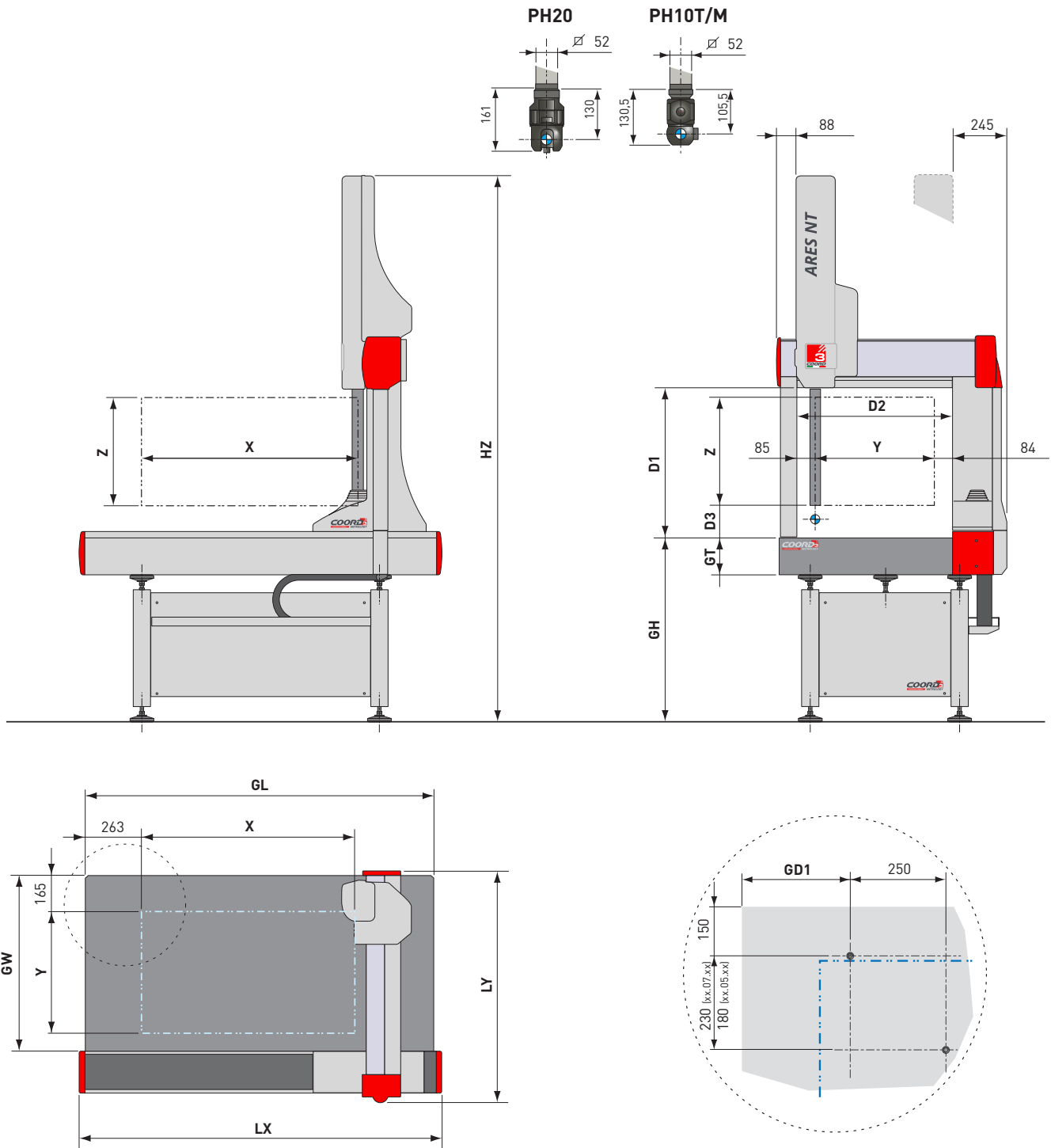

Models	Measuring Strokes			Overall Dimensions			Surface Plate					Daylights			Weights	
	X	Y	Z	LX	LY	HZ	Height	Thickness	Length	Width	Holes	D1	D2	D3 ⁽¹⁾	Max. Part Weight	Machine Weight
							GH	GT	GL	GW	GD1					
[mm]			[mm]			[mm]					[mm]			[kg]		
05.05.05	500	500	500	1180	1015	2393	720	140	1130	751	200	688	669	172,5	300	470
07.05.05	700	500	500	1380	1015	2393	720	140	1330	751	350	688	669	172,5	300	540
07.07.05	700	650	500	1380	1160	2429	750	170	1330	899	350	688	819	172,5	650	775
10.07.05	1000	650	500	1680	1160	2429	750	170	1630	899	350	688	819	172,5	700	925
12.07.05	1200	650	500	1880	1160	2429	750	170	1830	899	300	688	819	172,5	700	990
07.07.07 ⁽²⁾	700	650	650	1380	1160	2734	750	170	1330	899	350	838	819	172,5	650	800
10.07.07 ⁽²⁾	1000	650	650	1680	1160	2734	750	170	1630	899	350	838	819	172,5	700	950
12.07.07 ⁽²⁾	1200	650	650	1880	1160	2734	750	170	1830	899	300	838	819	172,5	700	1015

⁽¹⁾ NT serie, 177,5 mm on std

⁽²⁾ Only available in NT configuration

TECHNICAL CHARACTERISTICS

STRUCTURE

Coordinate Measuring Machine, CNC type, with aluminum alloy mobile bridge structure on granite table machine base

Guideways:

X axis: dovetail guideways machined into the granite table
Y axis: micromachined anodized light alloy extrusion
Z axis: micromachined anodized light alloy extrusion or Silicon Carbide (NT, NT XL)

Drive Method:

X axis: zero hysteresis friction drive on steel bar
Y axis: zero hysteresis friction drive on steel bar
Z axis: zero hysteresis friction drive on steel bar

Sliding System:

Air bearings on all axes

Motion Control:

DC servomotor on all axes

Thermal Compensation:

Multi-sensors temperature compensation system (total 4 sensors) in Option.

Measuring System:

High resolution (0,1µm) free floating linear scales mounted in carriers

PROBING SYSTEM

Manual Probe Head:

TPC3, MIH, MH20, MH20i, MH8, RTP20, PH6M

Motorized Probe Head:

PH10T, PH10M, PH20

Point-to-point Trigger Probe:

TP20, TP200, TP200B

Analog Contact Probe:

SP25M

Stylus and Probe Changer:

Fully automated stylus and probe changers

OPTION

Passive vibration insulating system
Active vibration insulation system (AVM)
Multi-wire cable

ENVIRONMENT

Temperature Range for Metrological Specification:

Temperature Range: 18 ÷ 22 °C
Max. gradient per hour: 0,5 °K/h
Max. gradient per day: 2,0 °K/24h
Max. gradient in space: 0,5 °K/m

Operating Temperature:

15 ÷ 35 °C

Relative Humidity:

40 ÷ 80 % (non condensing)

Acceptable Vibrations:

(vibration acceleration between peaks)

30 mm/s² from 1 to 10 Hz
15 mm/s² from 10 to 20 Hz
50 mm/s² from 20 to 100 Hz

Optional

- Metrology Room or CMM protection system

AIR SUPPLY

Air Consumption:

100 NL/min

Minimum Air Supply:

5 Bar (71PSI)

POWER SUPPLY

Power Supply Voltage:

230 V ± 10%; 50 Hz ± 2% (single phase)
115 V ± 10%; 60 Hz ± 2% (single phase)
(data for CC3-NT control)

WARRANTY

12 months from the date of acceptance test or a maximum of 15 months from date of shipment.

Distribuito da / Authorized Dealer / Vertrieben durch:



Perceptron North America Perceptron, Inc.

47827 Halyard Drive
Plymouth, MI 48170 - U.S.A.
Tel: +1 734 414 6100
info@perceptron.com

Perceptron EMEA (Europe, Middle East, Africa) Perceptron GmbH

Stahlgruberring 7
D - 81829 München - Germany
Tel: +49-89-960-980
emea@perceptron.com

Perceptron England Perceptron Metrology UK Ltd

Fort Dunlop, Fort Parkway
Birmingham, B24 9FE - UK
Tel: +44 121 6297794
uk@perceptron.com

Perceptron Italy COORD3 - Perceptron Italia Srl

Strada Statale 25, n°3
10050 Bruzolo (TO) - Italy
Tel: +39 011 9635511
italy@perceptron.com

Perceptron China Perceptron Trading (Shanghai) Co., Ltd.

Units B & C, 3rd Floor, Building 1
No. 180 ZhangHeng Road, ZhangJiang Hi-Tech Park
Shanghai 201204 - China
Tel: +86 21 3393-2262
china@perceptron.com

Perceptron South America Perceptron do Brasil Ltda.

Rua Helena 218, Suite 205 - Vila Olimpia
São Paulo 04552-050 - Brazil
Tel: +55 11 3044-1950
brazil@perceptron.com

Perceptron Japan Perceptron Asia Pacific, Ltd.

Shinbashi Annex 1F, 5-35-10 Shinbashi,
Minato-ku
Tokyo 105-0004 - Japan
Tel: +81 3 5425-1080
japan@perceptron.com

Perceptron India Perceptron Non-Contact Metrology Solutions Pvt. Ltd.

1GF 10 & 42, Omaxe Park Plaza, Shakti Khand -2,
Indirapuram, Ghaziabad - 201014, India.
Tel +91 44 4284-9610
india@perceptron.com